



# ZERO BRINE PILOT DEMONSTRATION

## DEMINERALIZED WATER PLANT (DWP) OF EVIDES IN BOTLEK, ROTTERDAM, THE NETHERLANDS

### Context

ZERO BRINE advances circular economy business model solutions to reduce industrial saline wastewater streams by recovering and reusing the minerals and water from the brine. Demineralized water is an essential commodity in the Botlek area, the industrial district of the port of Rotterdam, because it is required for many production processes. Reverse osmosis (RO) has become one of the main processes for producing demineralized water, but reverse osmosis alone is not enough to produce water of the required purity from the available water (fresh surface water), and several pre- and post-treatment processes are used. At the Evides DWP, one of the largest demineralized water production facilities in Europe, wastewater is treated by reverse osmosis combined with ion-exchange softening, among other technologies (see Graph 1).

### Objective

At the Demi Water Plant (DWP) of Evides in the Botlek industrial area, ZERO BRINE demonstrates the circular economy approach to treat industrial wastewater through redesigning the current brine treatment process from linear to a circular model recovering all the resources (see graph 1). A large-scale demonstration plant is tested at PlantOne, a test facility focused on sustainable technology and innovation in the Energy Port and Petrochemical cluster of Rotterdam Port, by using the waste heat from one of the factories in the port. The objective is to recover Ca- and Mg-salts as well as demineralized water from the discharges of the water-softening unit. The quality of the recovered products will be aimed to meet local market specifications.

### Technology

The demonstration plant comprises two sites combining residual heat and wastewater streams with the aim to eliminate brine effluent (zero brine discharge). At Evides (Site 1) the aim is to treat the regeneration solution of the ion exchange (IEX) unit (spent regenerant) and to recover valuable minerals and salts as well as water from this flow. This is done by nanofiltration, crystallization and evaporation of IEX (see Graph 2). Site 2 is an innovative design that aims to treat the reverse osmosis concentrate of DWP. Additionally, nyex is used to remove the anions and charged organic matter (see Graph 3).

### Business opportunities

Industrial saline impaired effluents (brines) are an environmental challenge and an economic opportunity. The following materials with potential commercial value are recovered on the two sites that will be used in the same factory by Evides or in the industrial area Botlek.

#### Site 1

- High purity magnesium & calcium
- Clean Water
- NaCl regeneration solution

#### Site 2

- Sulphate salts
- NaHCO<sub>3</sub>
- Clean Water
- NaCl regeneration solution

Graph 1: Schematic view of the current processes at the DWP plant at Botlek

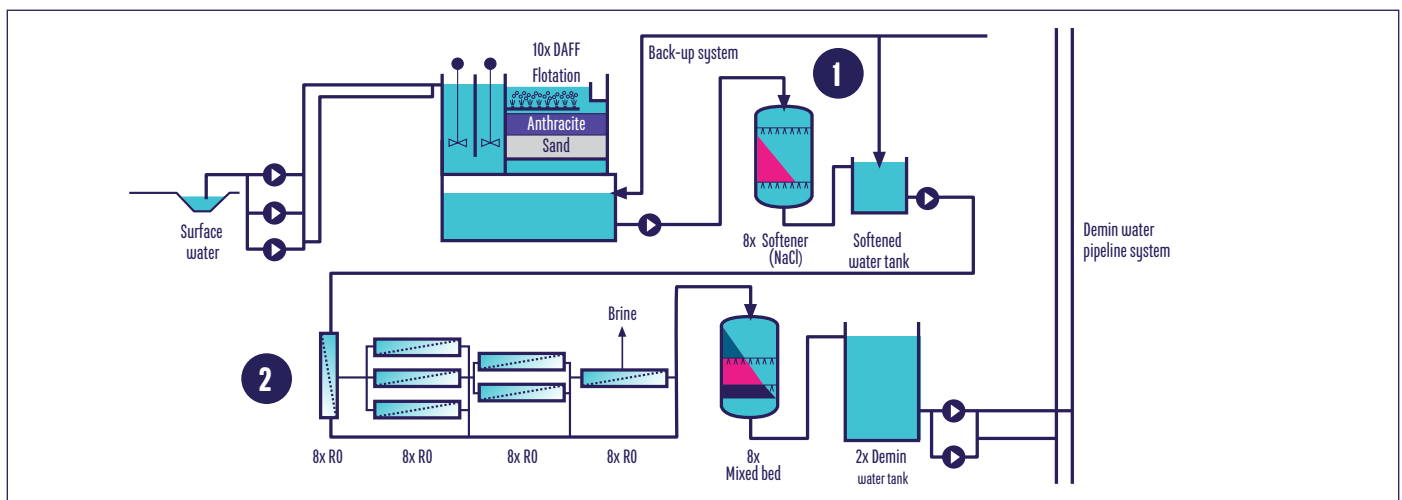

#### 1 Site 1: Technologies

Demonstration of Nanofiltration (NF) - Crystallizer (MF-PFR)  
Evaporation for treatment of Ion Exchange (IEX) Regenerates

#### 2 Site 2: Technologies

Nyex (TOC Removal) - Nanofiltration - Reverse Osmosis (RO) - Evaporation  
Eutectic Freeze Crystallization (EFC) for treatment of RO Concentrates

Graph 2: Site 1

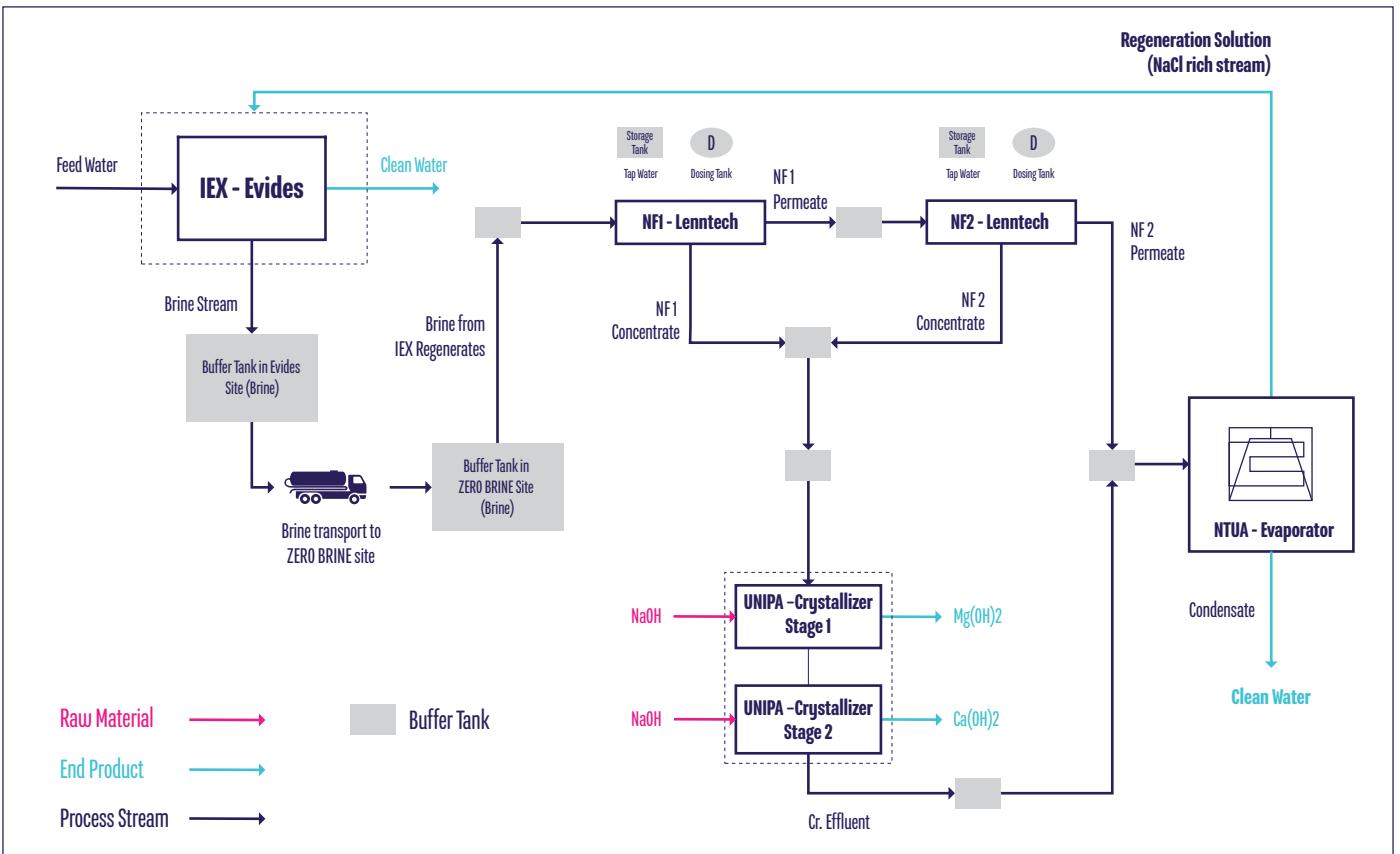

Graph 3: Site 2

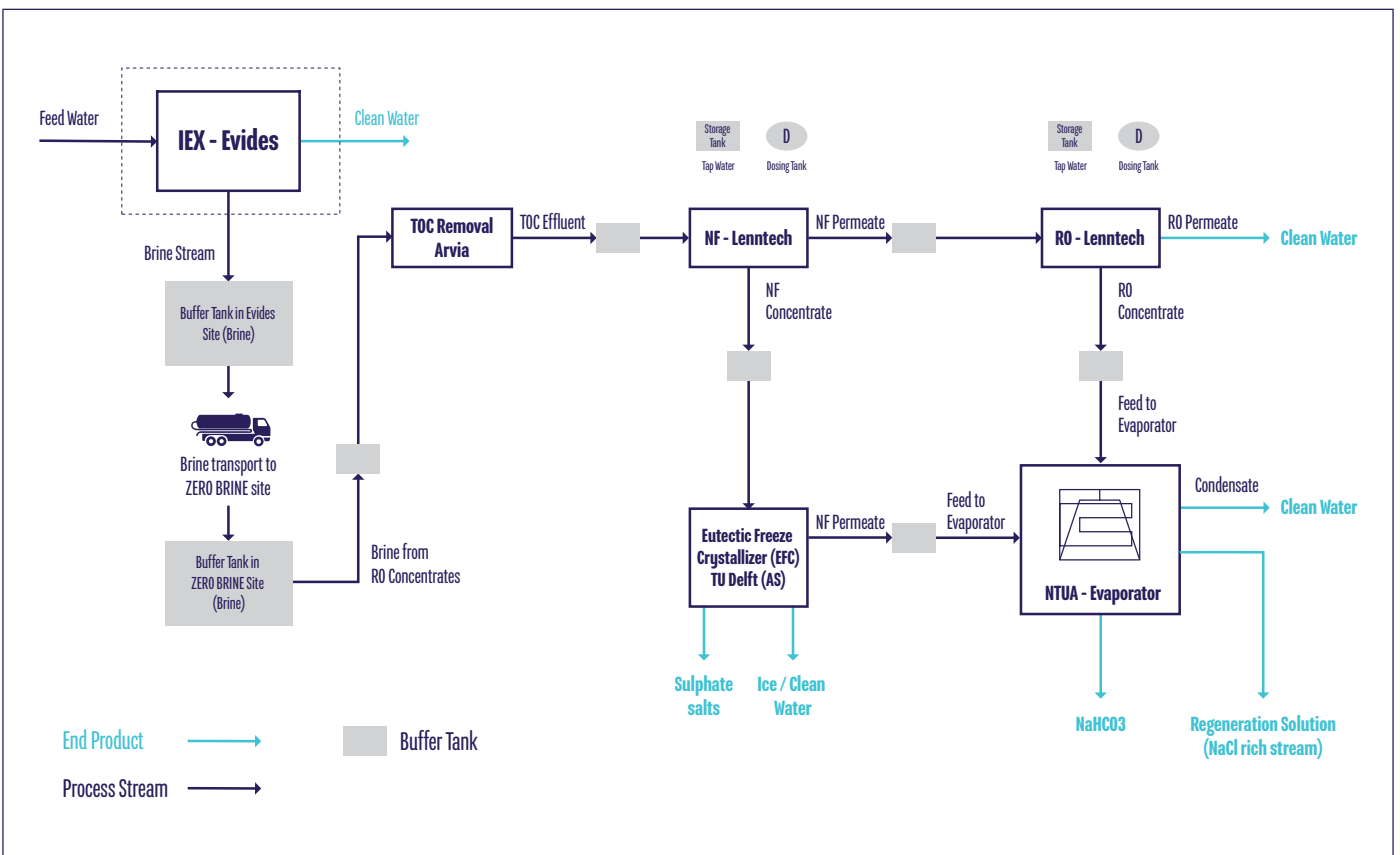

The ZERO BRINE project has received funding from the European Union's Horizon 2020 research and innovation programme under grant agreement No 730390.

#ZeroBrine

[www.zerobrine.eu](http://www.zerobrine.eu)

@zero\_brine\_