



ZERO BRINE PILOT DEMONSTRATION

ZORLU TEXTILE FACTORY IN LÜLEBURGAZ, TURKEY



1. Context

The management of industrial wastewater to comply with Zero Liquid Discharge (ZLD) has been receiving significant attention. The textile industry is one of the largest sectors in Turkey and makes up 10% of the country's GDP and employs around 750,000 people. However, the industry is also responsible for numerous environmental effects due to wastewater discharges which contain various chemicals, dyes, salts and other auxiliary materials from unit processes. The industry covers 1-3% GNP of the countries worldwide. Turkey ranks 5th and 6th in production of woolen and cotton products worldwide which makes up close to 40% of total export income and 10% of the industrial work force. Therefore, the implementation of a well-designed solution to prevent pollution along with the ZLD concept is highly favorable for both environmental concerns and economically.

The textile industry is a highly water intensive sector. Water consumption ranges between 60 to 120 L/kg for cotton products and 110-650 L/kg for wool. Water is utilized at various steps of the unit processes such as pre-treatment, dyeing or finishing. Processes require extensive water use for dyeing, rinsing, conditioning and finishing operations. The crucial parameters of discharges from textile enterprises include mainly organic constituents, dissolved solids, inorganic salts, color, sulfate and pH.

Salt usage is also significant in the textile industry. Salt is consumed for dyeing cotton or linen fabrics and acts as a raw and auxiliary material.

Physicochemical and biological treatment techniques are widely employed to treat textile industry wastewater to comply with local

discharge criteria. Moreover, membrane processes such as Nano-filtration (NF) and Reverse Osmosis (RO) are also utilized following conventional treatment methods as a tertiary treatment step to obtain a reusable stream. Membrane treatment for reuse is a very effective method for removal of ions and other pollutants. Reusable, high quality water is obtained using RO membrane processes.

RO on the other hand, results in the formation of highly polluted concentrate (brine) along with the high-quality, treated water stream. The impurities and pollutants in brine have serious adverse impacts on the environment. Principally, the brine discharges may cause environmental and ecological impacts on especially inland receiving water bodies such as lakes and rivers and may cause salinization of the soil which is one of the most severe environmental problems in agriculture.

The concept of circular economy and ZLD options are investigated for Zorlu Textile's integrated polyester yarn and cotton home textile manufacturing industry within the context of ZERO BRINE project. In this manner, treatment and recovery of the concentrated salt solution (brine) which can be reused in the dyeing baths of the textile plant and/or utilized as feed for salt production is targeted.

The demo project is primarily focused on the management of brine generated from the RO unit and developing an innovative brine treatment and recovery system. Brine from the RO treatment unit presents an important environmental concern due to the high concentration of impurities including various chemicals, salts, colors, hardness, alkalinity and nutrients. The primary difficulty to be overcome by this approach is the separation of hardness and color from brine while concentrating the salt solution which can, in turn, be used in textile dyeing processes. The recovered salt solution should also comply the criteria for textile dyeing process requirements.

Fig. 1 – Expected outcomes

Decrease salt consumption by 60%	Reduction in water consumption by 15%
Considerable decrease for CO₂ emissions due to salt recovery	Significant improvement of aquatic environments and protection of soil from salinization.



The ZERO BRINE project has received funding from the European Union's Horizon 2020 research and innovation programme under grant agreement No 730390.

#ZeroBrine



www.zerobrine.eu



@zero_brine_

2. Impacts

The ZERO BRINE project intends to reduce saline wastewater streams generated by industry by recovering and reusing minerals, water and metals from wastewater. ZERO BRINE aims at the development of innovative technological solutions of the highly saline wastewater problem for several industrial sectors including the textile sector. In this context, concentrate (brine) recovery of approximately 400 tons/year as NaCl is targeted for Zorlu Textile. Depending on the brine impurity, recovered concentrate is utilized for in-plant processes. The conditions for recovery is appraised, and off-site use may also be made possible. Moreover, production 80 Km³/year high quality water is also among the goals.

The results would have great impacts on the textile industry in achieving resource efficiency and improving sustainability due to the reduced consumption of process inputs, as well as the mitigation of greenhouse gasses accordingly. In this way, it is estimated that the reduction of 200 tons of CO₂ on an annual basis could be achieved.

Moreover, the similar technology and approach can be applied to other sectors of industry which generate saline discharges.

Fig. 2 – Conceptual scheme for textile pilot

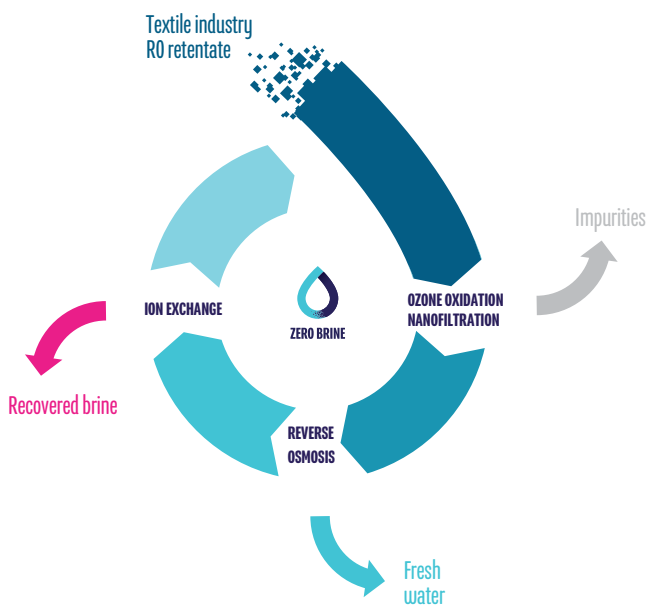

3. Business opportunities

Brine is a valuable resource for the recovery of salt and water. In this way, the purpose is to close the loop between the saline wastewater generated by process industries and to contribute the circular economy. The goal is achieved by means of innovative existing and new technologies to recover and reuse high quality end-products. By taking into account the demo system results, other various enterprises actively operating in the textile sectors will likely be encouraged. The solutions developed may sustain;

- I. compliance with the relevant regulations likely to be in force in the near future,
- II. economic benefits for the enterprise implemented ZLD approach due to the reduction in consumption of salt and water,
- III. improvements in visibility of the enterprise due to the increased concerns for environmental issues, and also relevant growth in export potential with good market value,
- IV. business opportunities foreseen for the companies involved wastewater treatment and reuse/recovery options,
- V. creation of new job alternatives for technical personnel in both textile or other relevant enterprises for various sectors including environmental fields (wastewater treatment and reuse companies).

4. Technology

Zorlu Textile industry wastewater is treated with physicochemical, biological methods and advanced treatment processes (activated carbon adsorption, ultrafiltration and RO) to obtain a reusable stream which is utilized for an energy company's cooling systems located near the Zorlu Textile. RO treatment consequently results in the generation of a highly polluted concentrate retentate (brine).

The proposed configuration of the brine treatment and recovery pilot system was developed based on the comprehensive characterization in bench scale tests, as well as the relevant assessments.

In this perspective, ozone oxidation and (NF) membrane processes are applied as the pre-treatment phase essentially to remove or mitigate impurities such as color, hardness, organic constituents and sulfate. NF provides 50-60% rejection of impurities whilst allowing 10-20% salt passage. Whereas, after NF membrane systems, RO is utilized as the concentration step for the NF permeate stream. At this stage, the concentrate stream of the RO unit is the recovered salt solution while the permeate of the RO unit is the reusable water – close to demineralized water quality – that can be reused for textile processing purposes.

The ion exchange softening process is also applied as the final step to acquire extra hardness removal of the recovered salt solution prior to the dyeing applications. This step would provide additional assurance as hardness is considered to be the critical parameter for textile dyeing processes. An activated carbon adsorption column and an UV oxidation unit are also provided within the pilot system to remove excess ozone remaining in the concentrate stream to provide protection for the membranes.



The ZERO BRINE project has received funding from the European Union's Horizon 2020 research and innovation programme under grant agreement No 730390.

#ZeroBrine

www.zerobrine.eu

@zero_brine_

Fig. 3 – General outline of the proposed system at Zorlu Textile

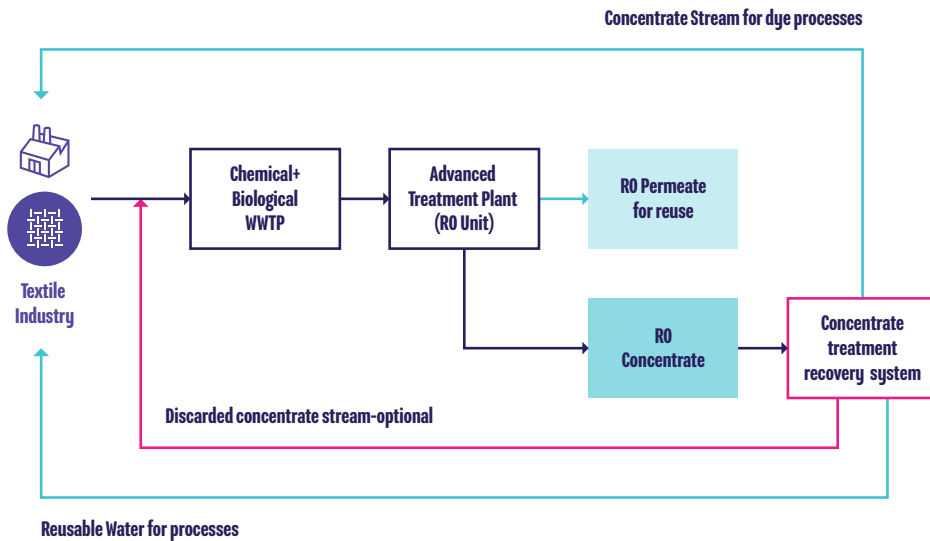
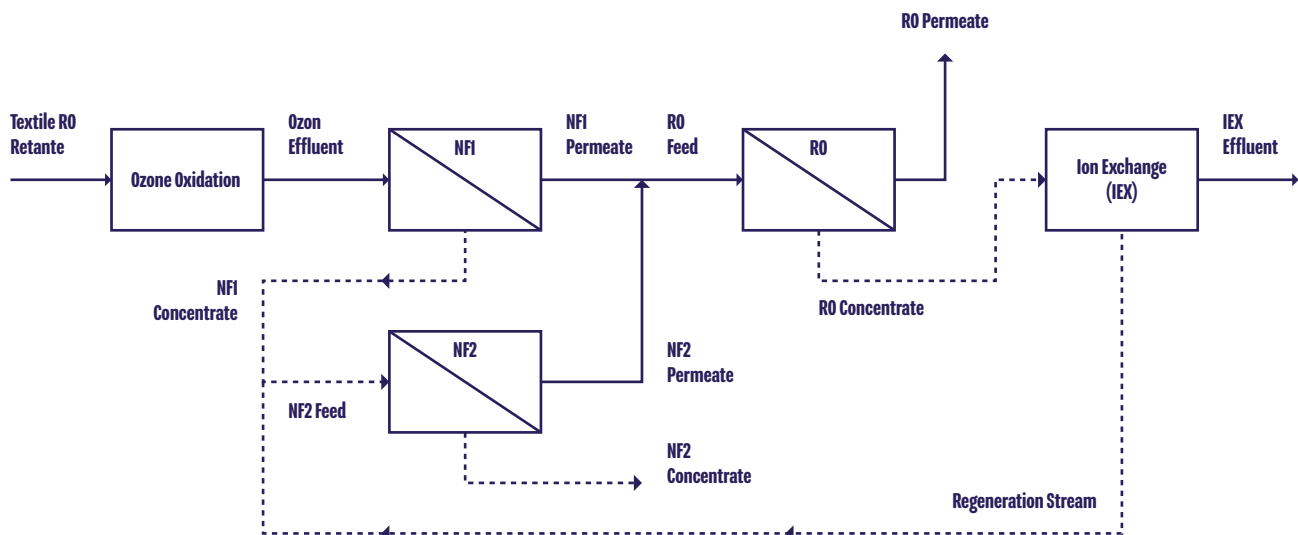

Fig. 4 – Process scheme of the applied technology for the pilot system



5. Key results and conclusions

The textile brine recovery pilot plant is intended for testing and verifying the proposed technology. It has been constructed and is being operated at the Zorlu Textile premises at Lüleburgaz, Kırklareli.

The pilot system involves a pretreatment stage with ozone oxidation, nanofiltration, concentration stage with reverse osmosis and, as a precaution, a softening unit by an ion exchange column. The pilot plant is capable of treating 300 L/hr of RO retentate discharged from advanced wastewater treatment facilities of Zorlu Textile. The developed process scheme results in 50-60% of recovery of NaCl for the dyeing processes. Whereas, the clean water recovery as permeate of the RO treatment unit would be 70-80%. Alternatively, this stream will be reused within the enterprise for various

purposes. The process design system allows the flexibility to be operated at relevant variable flow intervals. Moreover, the arrangement of the proposed treatment units and the piping connections could be varied to a certain extent depending on the operational conditions and the requirements throughout the operation period. Hence, by this approach it is anticipated to accomplish efficient recovery of salt solution for dyeing processes.

The ZERO BRINE textile pilot is capable of treating 300 L/hr discharged RO concentrate

50-60% of recovery of NaCl for textile dyeing

70-80% reusable pure water stream for process



The ZERO BRINE project has received funding from the European Union's Horizon 2020 research and innovation programme under grant agreement No 730390.

#ZeroBrine

www.zerobrine.eu

@zero_brine_